



Before using this FORK-N-HOG FORKLIFT,  
study and understand the entire Owner's  
Manual.

Serial Number \_\_\_\_\_



**FNH  
FORK-N-HOG  
FORKLIFT  
Owner's Manual**



**FORK-N-HOG FORKLIFT**  
EZG MANUFACTURING  
1-800-417-9272

EZG Manufacturing  
405 Watertown Road  
Waterford, Ohio 45786  
(740) 749-3512 or 1-800-417-9272  
Fax (740) 962-2037 [www.ezgmfg.com](http://www.ezgmfg.com)

# TABLE OF CONTENTS

INTRODUCTION.....	3
ABOUT THIS MANUAL.....	3
GENERAL INFORMATION.....	3
SAFETY INFORMATION.....	3
SAFETY PRECAUTIONS.....	4
CALIFORNIA PROPOSITION 65 WARNING.....	5
MACHINE DESCRIPTION.....	5
SPECIFICATIONS.....	6
OPERATING SAFETY.....	7
PRE-STARTCHECKS/ADJUSTMENTS.....	8
START / STOP PROCEDURE.....	9-12
SERVICE & MAINTENANCE.....	13-22
MAIN COMPONENTENTS.....	23-25
DRIVEWHEEL.....	26-27
STEERING SYSTEM.....	28-30
BRAKE SYSTEM.....	31-32
HOISTING SYSTEM.....	33-36
ELECTRICAL SYSTEM.....	37-39
HYDRAULIC SYSTEM.....	40-41
NOTES / SERVICES RECORDS.....	42
WARRANTY.....	43
WARRANTY REGISTRATION.....	44

# INTRODUCTION

Congratulations on purchasing one of the finest pieces of construction equipment on the market today! If this is your first EZG Manufacturing product, you will not be disappointed. If you have previously owned an EZG Manufacturing product, you will find the same high quality and dependability that you have come to expect from EZG Manufacturing.

## ABOUT THIS MANUAL





The purpose of this manual is to inform the owner/employer/and the operator, how to safely operate this piece of equipment, and make them aware of any hazards. It also contains important information regarding assembly, set up, operation, and maintenance. It is the Owner/Employer's responsibility to make sure that anyone who operates this machine understands all safety warnings. If you do not understand any items in this manual, please contact the dealer where this product was purchased, or the manufacturer at the number listed throughout this manual. If you have any suggestions about how to make this manual easier to understand, contact the manufacturer. Keep this manual available for reference wherever this piece of equipment is being used and make it available to any operators.

## GENERAL INFORMATION

Illustrations in this manual may show details or components that may not be the same as your machine. Continuing improvements to the design of this machine may have caused changes that are not included in this manual. The information in this document is subject to change without notice.

## SAFETY INFORMATION

The following safety symbols and signal words will be used throughout this manual and on the product, for your safety and the safety of others, please become familiar with their meaning and heed their warnings.

	This symbol, either used alone or with a signal word, is used to call your attention to instructions involving your safety and/or the safety of others. Failure to follow these instructions will likely result in personal injury or death.
 <b>DANGER</b>	This signal word is used to identify a hazard which, if not avoided, will result in death or serious injury.
 <b>WARNING</b>	This signal word is used to identify a hazard which, if not avoided, could result in death or serious injury.
 <b>CAUTION</b>	This signal word is used to identify a hazard which, if not avoided, could result in minor or moderate injury.
<b>NOTICE</b>	This signal word is used to identify a hazard which, if not avoided, could result in property or equipment damage. It also may be used for special instructions related to performance, maintenance or general items.

# SAFETY PRECAUTIONS



## WARNING

**Failure to obey the following safety instructions could result in DEATH or SERIOUS INJURY.**

Read and understand this entire manual before operating the Fork-N-Hog Forklift.

For your safety and the safety of others, replace any missing or damaged warning decals by contacting the manufacturer at 1-800-417-9272.

Make sure anyone operating the Fork-N-Hog Forklift is thoroughly familiar with its operation. Keep all unauthorized and untrained personnel, especially children, away from operating the Fork-N-Hog.



Improper maintenance can be hazardous. Read and understand this section before you perform any maintenance, service or repairs.

## General Safety

- The Fork-N-Hog should only be lifted by qualified personnel.
- DO NOT lift the machine by the ROPS.
- DO NOT lift the machine from the bottom side using forks. Mechanical and electrical components can be damaged from this lifting position.
- Never exceed the rated capacity of the piece of lifting equipment being used to lift the Fork-N-Hog.
- All rigging should be inspected per OSHA requirement.
- Never stand under a suspended load

# MACHINE LIFTING INSTRUCTIONS



## WARNING

Failure to obey the following instructions could result in **DEATH** or **SERIOUS INJURY**.

Use the nylon lifting strap and the three (3) rigging points provided with the Fork-N-Hog.

- Inspect lifting strap prior to use.
- Slide the seat forward prior to positioning the lifting strap.
- Rig one end of the strap through the cage (*Figure 1*) and hook to rigging point on the top of the mast (*Figure 2*).

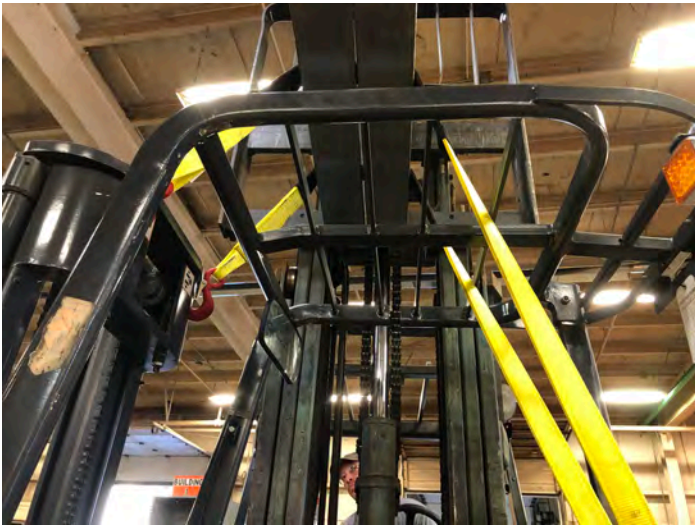

Figure 1



Figure 2

- Loop the center point of the strap into the pin opening and replace the pin (*Figure 3*).
- Position the forks of the lifting machine above the cage and below the straps (*Figure 4*).
- Ensure that the sleeve is over top of the forks to prevent unnecessary wear to the strap when lifted.

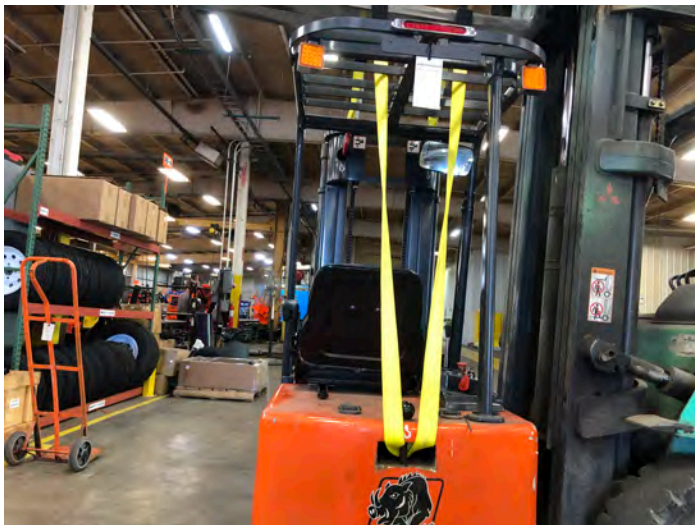

Figure 3



Figure 4

# MACHINE LIFTING INSTRUCTIONS



## WARNING

Failure to obey the following instructions could result in **DEATH** or **SERIOUS INJURY**.

- Begin to lift the machine until the straps have a slight amount of tension (*Figure 5*).
  - Stop and double check the correct positioning of the hook ends and the counterweight pin.
- Continue to lift the machine to the desired elevation (*Figure 6*).



*Figure 5*



*Figure 6*

## California - Proposition 65 Warning

Engine exhaust and some of its constituents, and some dust created by power sanding, sawing, grinding, drilling, and other construction activities contains chemicals known to the State of California to cause cancer, birth defects and other reproductive harm. Some examples of these chemicals are:

Lead from lead based paints - Crystalline silica from bricks -Cement and other masonry products -Arsenic and chromium from chemically treated lumber

Your risk from these exposures varies, depending on how often you do this type of work. To reduce your exposure to these chemicals: ALWAYS work in a well ventilated area, and work with approved safety equipment, such as dust masks that are specially designed to filter out microscopic particles.

## MACHINE DESCRIPTION

The 24-volt battery powered EZG Fork-N-Hog Forklift is unique in its shape, heavy-duty yet compact carriage and ergonomic, comfortable operation. Designed for narrow passages and small operating areas, the Fork-N-Hog can easily transport over one US ton of goods in small freight elevators, cargo containers and enclosed trailers. With the special three-point drive designed framework, variable wheelbase and the rear drive unit, the mini Fork-N-Hog has excellent stability and a 90 degree turning angle capability.

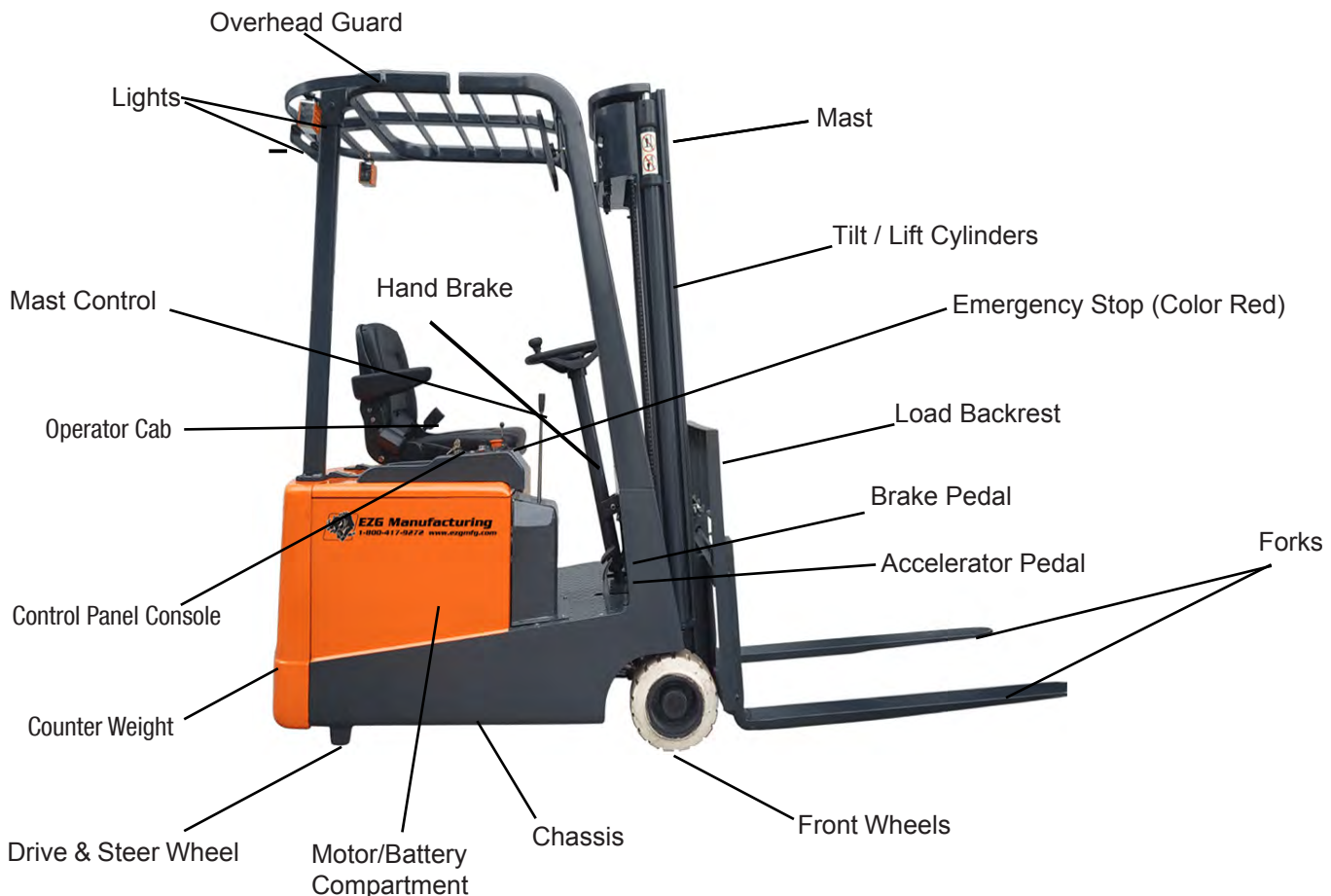

# SPECIFICATIONS

**Table 1 The Main Technical Parameters**

Type	Unit	FNH9
Capacity of lift loading Q	lb (kg)	2,200 (1000)
Distance of load center C	in (mm)	16[20*] (400{500*})
Lifting high h3	in (mm)	126 (3,200)
Free lifting high* h2	in (mm)	63 (1,600)
Length of the fork b3	in (mm)	32[39*] (800[1000*])
Displacement to side of the fork* b2	in (mm)	Left/right 4 (100)
Type of lifting		Hydraulic-electronically controlled
Lifting speed	m/min	>5
Lowering speed		Adjustable type
Tilt of lift mast ~ forward/backward	<	2°/5°
Height of mast h1	in (mm)	75 (1,900)
Height of mast extended h4	in (mm)	142 (3,600)
Height of overhead guard h5	in (mm)	75 (1,900)
Height of seat from floor h6	in (mm)	33 (850)
Length of the fork back to truck rear L2	in (mm)	50 (1,260)
Width of carriage B	in (mm)	32 (800)
Distance between wheel bases	in (mm)	35~41 (900~1,030)
Distance between wheels	in (mm)	26 (660)
Height of truck body from floor Y	in (mm)	4 (90)
Turning radius Wa	in (mm)	49 (1,240)
Type of steering		Steering wheel mechanical
Type of drive		Wheel electronically controlled
Driving speeds (with load/without)	mile(km)/h	4.3 (7.0) /6.0
Speed control		Stepless adjustable system
Gradeability	%	8
Driving brake		The drum brakes in the front wheel hubs
Stopping brake		The hand brake Mechanical
Battery	24V	D-385
Weight of battery		858 (390)
Weight of truck (include battery)	lb (kg)	3,410 (1,550)
Driving motor - Compound wound dynamo	kw	2
Lifting motor - Shunt wound dynamo	kw	2.8
Wheels (front/rear)		Solid tires
Dimensions of front wheels (2)	mm	φ267×127×165
Dimensions of driving wheels (rear) (1)	mm	φ267×127×165

Note: 1. The type of the items with \* can be chosen according to the demand of the customer.  
 2. The producer reserves the right to modify the above parameter.



## OPERATING SAFETY

Before starting work, check the brakes, steering wheel, tires, horn, hydraulic system, battery capacity, etc. to ensure proper that they are working properly.

- Never use the forklift if you have not been specifically trained and authorized to do so.
- Read the data carefully about the Forklift capacity, the load weight, and the load curve. Never exceed the load capacities specified on the data plate.
- Never drive the Forklift with wet or greasy hands or shoes.
- Do not install other implements around the head guards or the carriage that restrict operation or visibility.
- Buckle seat belt prior to operating forklift.
- Never activate control levers if you do not know their purpose. Activate controls only correctly seated in the driver seat and facing straight and level.
- Never drive over electric cables or hoses unless they are appropriately protected.
- Never drive over soft surfaces, uneven ground, any openings above 2" (5cm). Also never drive over platforms or scaffolds that are not sufficiently safe considering the total weight of the Forklift and the payload.
- While driving the Forklift, you should always maintain the correct driving position. Never stick your legs outside the Forklift and never put your hands and feet between the moving parts of the lift.
- While loading goods, be sure to check the quality of the pallets, never put the goods on damaged pallets.
- Avoid starting suddenly, sharp braking, reversing, and changing direction suddenly as the Forklift may tip over to the front or the side.
- If the Forklift tips over, remain seated, grasp the steering wheel tightly, keep your body in the center of the Forklift as much as possible to avoid being trapped under the machine.
- Keep battery charged, periodically checking to ensure the level of the electrolyte and the density of the electrolyte match. Never add liquid.
- Keep each part of your Forklift lubricated and the external appearance of your Forklift clean.
- Check that wheel nuts and all other connecting hardware is properly secured.
- Check that the brake system is in good operational condition.
- Do not turn the steering wheel when the Forklift is stopped and unloaded to avoid excess stress on the steering system.
- Park the Forklift on firm, flat ground and set the hand brake on when the Forklift is stopped.

# PRE-START CHECKS / ADJUSTMENTS

## Adjustment of the Seat

The driver seat can be adjusted to several positions in front or back for optimal driving comfort. To adjust seat position, press the adjustment lever under the seat (not shown), pull the seat to the appropriate position, forward or back, and when adjusted to the appropriate position, release the lever and attempt to physically push the seat forward and backward to ensure that it is locked in place. The adjustment of the seat is complete.

**NOTE:** Adjust the seat only when the the Forklift is turned off. Ensure the seat is locked in place

**Warning:** Before adjusting the rake of the steering wheel, you should park the Forklift and apply the hand brake.

## Adjustment of the Vertical Tilt of the Steering Wheel

The rake of the steering wheel can be adjusted to personal operation habit. To adjust the rake of the steering wheel, use the method described below:

Loosen the locknut connecting the carriage under the steering column with the wrench and push the steering column forward or pull the steering column backward lightly. Position the steering wheel as required and then re-tighten locknut.

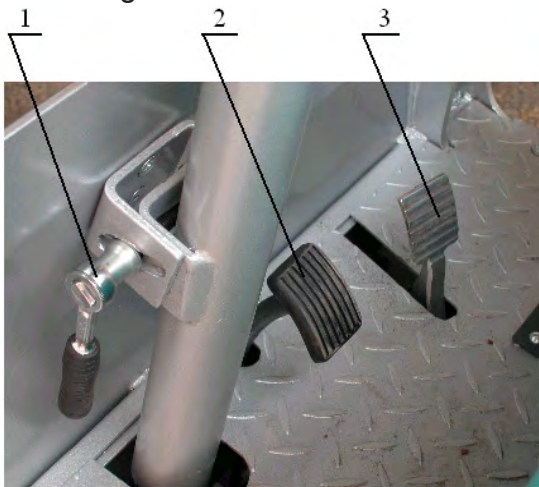
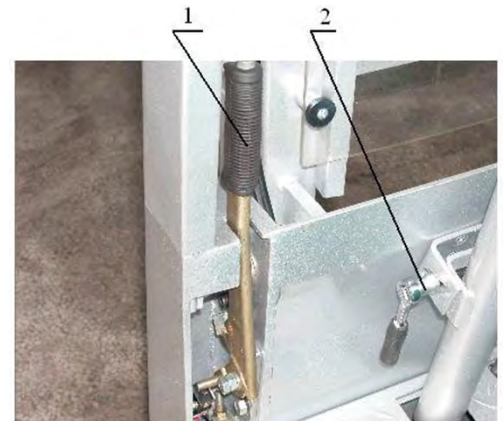

Fig 2

- 1 The steering column locknut.
- 2 The brake pedal.
- 3 The accelerator pedal

1. The hand brake
2. The steering column locknut



# START/STOP PROCEDURE

## Starting & Stopping the Machine

To start the FNH, insert the key in the **Starting Switch** (7) switch and turn it to the right. Turn the **Emergency Stop Switch** (3) in a clockwise direction to reset (out position). This activates the control system. (Consoles “A” and “B” are shown as references)

To stop the Forklift, take your right foot off the accelerator pedal. Press the brake pedal until the Forklift has come to a complete stop. Completely lower the forks and apply the parking brake (hand brake) and remove the key from the switch.



Console “A”

## Battery Capacity Display

The Battery Capacity Meter can indicate the battery capacity level and shows the total operating time (total hours) on the battery. Check to see that the battery has sufficient capacity for operation.

## FNH Forklift Operation

Once the FNH is started:

- Lift the **Forks** about 4 inches (10 cm) from the floor.
- Release the **Hand Brake** (Figure 4 – 1).
- Place the **Direction Lever** (Figure 1 - 2) in the required direction (forward/reverse).
- Use the **Speed Selection Switch** (Figure 1 - 1) to select the desired operating speed of Slow (tortoise) or Fast (rabbit).
- Press the **Accelerator Pedal** (Figure 2 – 3) slowly until the required speed is reached,



- 1 Speed Selection Switch
- 2 Direction (Reverse/Forward) Lever
- 3 Emergency Stop Switch
- 4 Battery Capacity Meter
- 5 Horn Button
- 6 Light switch
- 7 Starting switch

Fig.1 - The Fork-N-Hog Forklift Console “B”

## Important notice:

**If you lose control of the Forklift during any kind of maneuver, press the red Emergency Stop (3 button on the right-hand side of the seat immediately to stop all operating power.**

When turning the Forklift, you should slow down as turning at fast speeds is dangerous.

The power gradeability of the electric FNH is 8%. When starting on an uphill slope, place the Speed Selection Switch in the slow (tortoise) position and fully engage the accelerator pedal of the Forklift to acquire the maximal gradeability.

# START/STOP PROCEDURE

In the case of downhill slope, release the accelerator pedal to obtain reverse current braking. If reverse current braking cannot control the speed of downhill slope (the downhill slope speed is too fast), the brake pedal should be pressed at this time to slow the Forklift.

**Warning: Never leave the Forklift before applying the parking brake (hand brake).**

## **Directional Lever (Forward / Reverse)**

To change direction, use the Direction Lever on the console (as shown in the fig.1 - 2). Push the lever forward so the Forklift moves forward and pull the lever back to move the Forklift backward. Allow the Forklift to stop between shifting.

## **Accelerator Pedal**

Be aware of the Forward/Reverse selection. Press the **accelerator pedal** (fig. 2 - 3) slowly with your right foot for the Forklift to move forward or backward.

**Warning: Never press the accelerator pedal with excess force to avoid the Forklift getting out of control resulting in an accident.**

## **The Foot Brake Pedal**

To stop the Forklift, take your right foot off the accelerator pedal, and press the **brake pedal** (fig. 2) until the Forklift has completely stopped.

**Do not press the accelerator pedal and the brake pedal at the same time as that will burn out the electric component.**

## **The Emergency Stop Switch Button**

If the Forklift suddenly gets out of control, you smell/see any fumes or any other potentially dangerous conditions, immediately press the red **Emergency Stop Switch** on the console to immediately cut off the power. Only after examining and correcting the unsafe condition should you turn on the Forklift. To turn on the Forklift rotate the red Safety Switch in a clockwise direction lightly until the button springs up and resets.

**Warning: Never turn on the power if you have not found the cause of the problem.**

**Do not use excess force on the red Emergency Switch to avoid possible damage.**

## **The Horn and the Reversing Buzzer**

For driving the Forklift safely, the Forklift is equipped with a horn (Fig. 1 – 5) and a backup alarm reversing buzzer. The Horn Button on the console. Press it lightly to sound the horn. The Backup Alarm Buzzer is actuated when the Direction Lever is moved into the reverse direction.



# START/STOP PROCEDURE

## Adjusting the Mast Position to Ensure a Stable Load

- Do not tilt forward with a load with the forks elevated except when picking up a load. When stacking a load, tilt the mast backward just enough to stabilize it.
- When working with a maximum capacity load, tilt the mast backward and position the load so the heaviest part is against the carriage.
- Move the forklift with the mast tilted back.
- When you are ready to stack the load, tilt the mast forward very slowly, and never travel with the mast tilted forward.

## Adjusting the Fork Positions

- Level the forks before lifting a load.
- Place the forks as far under the load as possible.
- Center the weight of the load between the forks. Adjust forks manually or with a fork positioner.
- Tilt the mast back to stabilize the load.

## Lifting the Load

- Ensure there is adequate overhead clearance before lifting the load.
- Slowly lift the load and tilt the mast backward slightly to stabilize it.
- Slowly return the lift control to the neutral position.

## Lowering the Load

- Ensure the load is secure.
- Tilt the mast back carefully to stabilize the load.
- Slowly move the forklift away from the stack.
- Stop the truck and return the mast to the vertical position before lowering the load.
- Lower the load so that the lowest point is 6-8 inches (15-20 cm) from the floor.

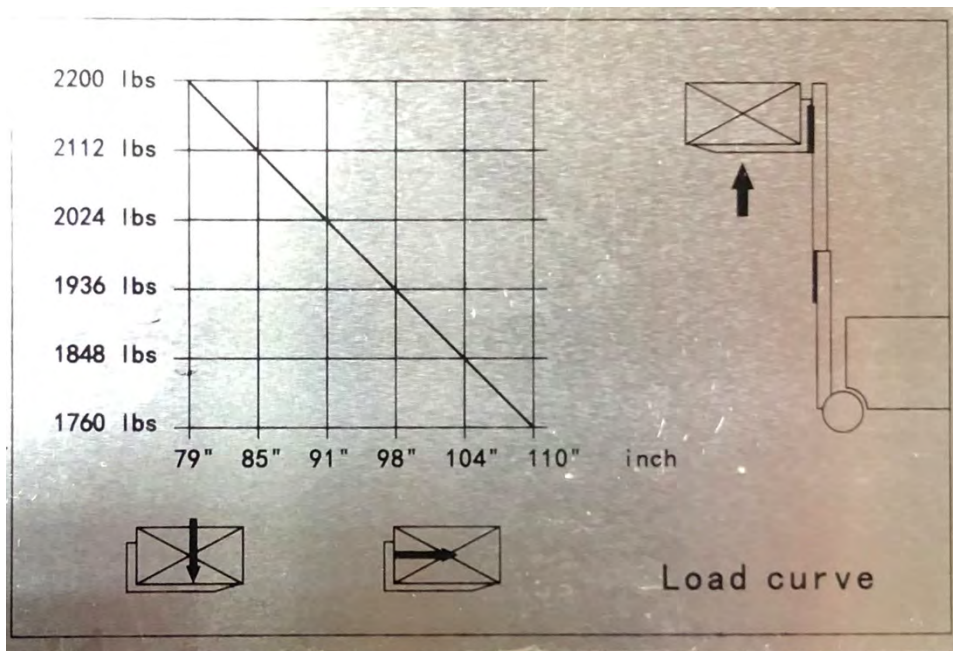

# SERVICE & MAINTENANCE

**Note:** Before carrying out any repair, inspection, or maintenance operations, check that you have applied the parking brake, lowered the forks to floor level and removed the key from the switch. Always pull the plug out of the battery before carrying out any operations on the electrical system.

For general cleaning of the Forklift, use dry air and damp rags; never use pressure washing, solvents, or gasoline to avoid damage to Forklift components equipment.

Maintenance and inspection should be carried every 10 hours. If the Forklift is used frequently, the interval of maintenance must be shortened.

**Warning: The inspection, maintenance, adjustment and repair operations must be carried out by qualified and authorized personnel only.**

Connect the battery only when necessary for testing.

Take all the necessary precautions and other measures when carrying out any maintenance, adjustment, repair & inspection and when the drive wheel is raised off the ground.

## The Usage and Maintain of the Storage Battery

### The safety rules of the battery

Remember that the battery generates gases that may cause it to explode on contact with flames or sparks.

- (1) Connections must be coated with anti-acid grease or neutral Vaseline.
- (2) Do not tap current from the battery with plugs or clips for makeshift contacts.
- (3) Check whether the plastic protections of the connections are positioned correctly.
- (4) No smoking should be allowed when repairing a battery or while it is charging.
- (5) Never rest tools or metal parts on the battery.
- (6) Keep the metal cowling of the batteries clean and dry.

Checking the electrolyte in the battery

The most important thing to be carried out on the battery is measurement of the density of the electrolyte as this indicates the state of the charge.

The density of the electrolyte is measured with a density meter by inserting this in the element to be measured and tapping a sufficient quantity of electrolyte to bring the float to the surface. Read the value from the specific weight piece in the density meter. The density of a completely charged element is around 1:1.27~1:1.28 at 20~25°C. Density drops as the battery runs down. Running down of the battery must be interrupted when the density of the electrolyte reaches 1:1.25. If the temperature of the electrolyte is other than 25°C when the check is made, the value drops by approx. 7g/l for an increase of 10°C.

### Top up the electrolyte

The electrolyte used in lead batteries is a solution of sulfuric acid in distilled or demineralized water.

A drop in the level of the solution in the elements is normal. This is caused partly by evaporation and partly by the electrolysis that occurs during the final charging phase. One of the most important maintenance operations on the battery is therefore topping up of the water to keep the level of the solution required. Follow the rules indicated below:

- Always use distilled or demineralized water.
- Keep the level approx. 10mm slightly above the element.
- Do not use tap water or pure water.
- Do not overfill, avoid spilling of the acid that causes reduction of element capacity.

# SERVICE & MAINTENANCE

## Charging the Battery

- Open the plug of each element.
- Check the level of the electrolyte. If the level is under the standard value, you must charge the battery.
- Insert the plug of the battery into the battery charger socket. Do not insert the plug of the charger into the electric appliances control plank socket.
- Start charging the battery.
- After recharging, check the level of the electrolyte.
- After 250 hours of usage of the battery, check the tightness of the terminals and protect with anti-acid grease or neutral Vaseline.

## Replace the Battery

Because the battery installed in the Forklift is welded, when replacing the battery, you should use the hook to lift out the battery and the metal box. Insert the new battery and connect the electrical wire. The battery is ready to be used.

The method above can also be used in the enterprise for continuous work. The spare battery and the battery within the Forklift can be used alternatively, charging the spare battery outside while the Forklift battery is being used.

## The Motor

The driving motor and the lifting motor are all direct current dynamos that make up of stator and rotor. The commutators on rotor conduct electricity by friction with the carbon brush, so carbon or copper powders are produced when used for a long time. Suggest that you blow clean compressed air onto the commutator to remove any dust and the carbon or copper powder after a period of time. At the same time, inspect and check the roughness of the commutators and the protrusions between the blades.

If there are any spots of rust on the commutator, clean the armature with fine grain emery paper. If there are obvious signs of abrasion or scratches on the commutator and the mica between the blades have come to the surface, rotor must be taken out and re-machined on the lathe and scrape its entire surface to lower the mica. This process needs to be done by an expert personnel with appropriate tools to lower the mica, to deburr the corners of the blades and smooth the commutator.

Inspect and check periodically to ensure they are evenly worn out without any signs of abrasion or scratches and the brushes are free inside their housing. When replacing the brushes, follow the instructions of the "Parts Catalog". After replacement, attach the brushes so that they adhere completely to the commutator.

Inspect and check periodically to ensure they are evenly worn out without any signs of abrasion or scratches and the brushes are free inside their housing. When replacing the brushes, follow the instructions of the "Parts Catalog". After replacement, attach the brushes so that they adhere completely to the commutator. After attaching new brushes, remove any carbon dust between the blades of the commutator with dry compressed air.

If the motor of the Forklift makes an unusual noise when operating, you should inspect and replace the bearings.

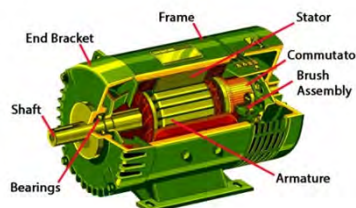

Typical Electrical Motor



## ELECTRIC SYSTEM PRINCIPLE DIAGRAM

<p>M1 model 1 low speed</p> <p>M2 model 2 high speed</p> <p>A forward</p> <p>B reverse</p> <p>5KΩ regulating speed potentiometer</p> <p>K1 key switch</p> <p>K2 locking for the other circuits</p> <p>A1,A2 the armature</p> <p>S1,S2 magnetic field</p> <p>Z1 main contactor</p> <p>ZS1 main contactor coil</p> <p>Z2 pump motor contactor</p> <p>ZS2 pump motor contactor coil</p>	<p>m1 Compound wound dynamo motor</p> <p>m2 oil pump motor</p> <p>V1 inching switch for lifting</p> <p>V2 inching switch for tilt</p> <p>V3 inching switch for sideshift</p> <p>W horn</p> <p>N1 horn button</p> <p>T1 big pilot light in front</p> <p>P1 fuse (100A)</p> <p>P2 fuse (20A)</p> <p>P3 fuse (20A)</p> <p>J1 relay for the pilot light in front and back</p> <p>Js relay coil</p>
--	--

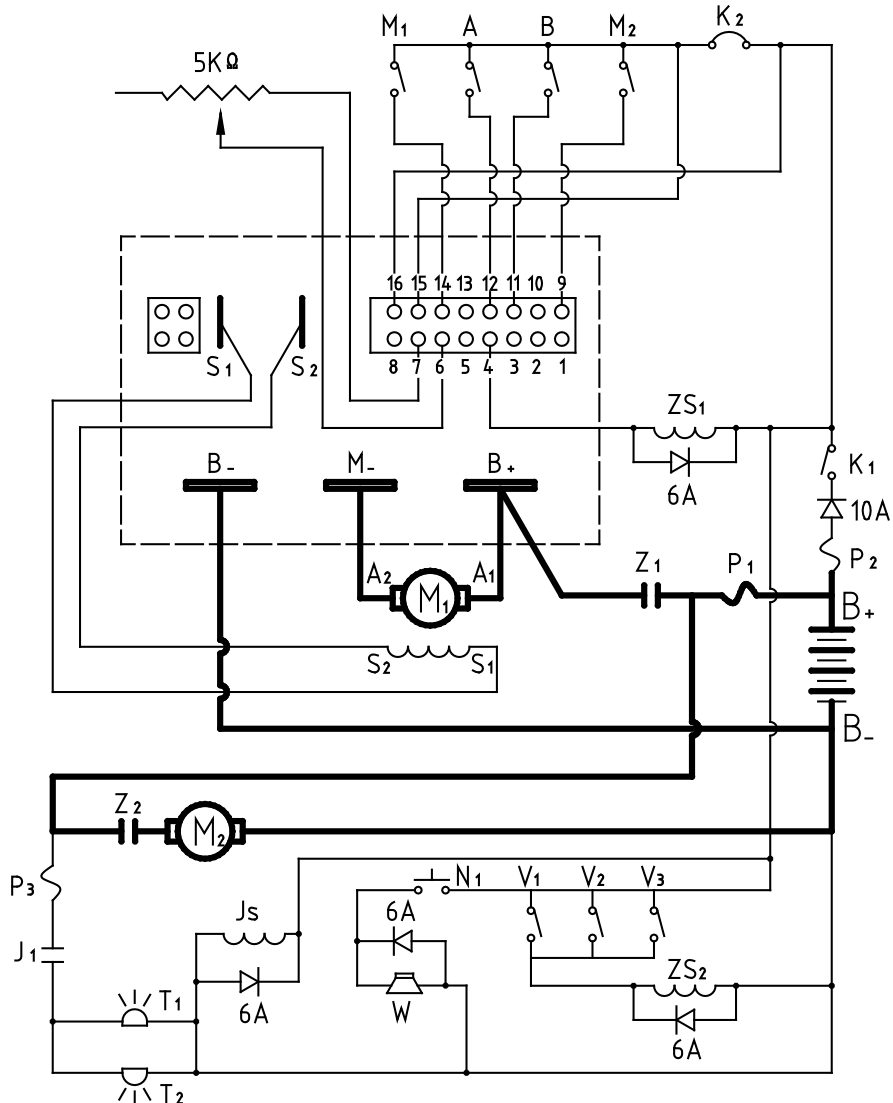

# SERVICE & MAINTENANCE

## The electrical control system

The electrical control system adopts the Compound Wound Dynamo mainboard of 1243 type that the American CURTIS produces. All control functions are carried out logically by the microprocessor. According to MOS technology at high frequency and the valid control of the microprocessors, the system has the following characteristics:

- Snuffer of the coils of the contactors inside the logic, assuring absence of arcs on the contacts of these.
- A microprocessor supports the EEPROM that makes it possible to modify, within a prefixed range, some of the adjustment parameters using an external console.
- Have the protective function when open circuit and short circuit happens.
- Diagnostics with output of the type of fault by means of the external console. Logging of the last 5 alarms with related electric current value and temperature that can be displayed from the console.
- Programming of the controller can improve response at low speeds.
- A tight container is also mounted to assure optimal protection against splashing and against dust, chip, or small objects.

**Warning: Do not connect the anode and the cathode of the battery to the wrong conjunction bolt of controller, and do not insert the plug of the charger into the electric appliances control plank socket that will burn out the controller.**

## The Meter for Examining Malfunction (table 2)

The state LED has been installed on controllers 1243 and can be seen from the window of the label on top of the controller. When the controller or the input of the controllers is out of order, the state LED will show the malfunction code. When the operation process is in order, the state LED will be stable. If the controller has encountered a fault, the two-digit indication code of the fault will flash continuously until the fault is corrected. For example, the fault code "3,2" indicates that the main conductor is in touch with other. Show as:

Table 2 The state LED and the malfunction code

LED	Code	Explain
All light off	■■■■■■■■■	The source or controllers are bad
All light on	□ □ □ □ □ □ □ □ □ □	Controller or microprocessor breakdown
0,1	■ □	The controller work; No breakdown
1,1	□ □	The sensor of the electric current break- down
1,2	□ □ □	The hardware breakdown
1,3	□ □ □ □	the breakdown in the M- or electrical engineering output
1,4	□ □ □ □ □	The SRO break down
2,1	□ □ □	The accelerator breakdown
2,2	□ □ □ □	The breakdown in the emergent reverse check electro circuit
2,3	□ □ □ □ □	The high pedal (HPD) breakdown
2,4	□ □ □ □ □ □	The breakdown in the low import of the accelerator
3,1	□ □ □ □	The overflow in the driver of the contactor or the short circuit of excitation coil
3,2	□ □ □ □ □	The adhesive connection of the main contact
3,3	□ □ □ □ □ □	The open circuit of the coil circuit
3,4	□ □ □ □ □ □ □	No contact for the contactor
4,1	□ □ □ □ □	The battery electric voltage is low
4,2	□ □ □ □ □ □	Over press
4,3	□ □ □ □ □ □ □	Cutting off owing to the overheat/ overcool
4,4	□ □ □ □ □ □ □ □	The breakdown in anti-moor

## THE HYDRAULIC LIFTING SYSTEM

Each lever controls one hydraulic system only. The position of the control lever, distribution of hydraulic line will control the different speeds. With the manipulating lever activated, the supplementary dynamoelectric switch activates the oil pump motor which starts to turn synchronously, to export the hydraulic oil, and allows movement of the related hydraulic parts. In order to ensure the pressure safety of the hydraulic system, the pressure overflow device is installed on the hydraulic valve. Once the pressure exceeds the safety value, the pressure overflow valve will overflow to unload automatically

**Notice: Do not adjust the pressure unit on the hydraulic valve at your discretion.**

### The Lifting System

The lifting unit consists of a fixed upright and a mobile upright for the dynamoelectric counterweight Forklift of series of CPD-F type. The mobile upright can move up and down by means of stretching and shrinking the cylinder. The high strength forged steel forks slides on the mobile upright by means of the traction of the high tensile strength chain to load and unload the goods safely. (Fig.4)

### The Hydraulic Cylinders

The dynamoelectric counterweight Forklift of series of CPD-F type has common type and standard type. The common type is fitted with two lift cylinders outside the fixed upright while the standard type is additionally equipped with a third central cylinder that can be used inside the container. All cylinders are plunger type cylinders.

There is a double acting plunger type cylinders that is used to tilt the uprights in the bottom of the uprights.

The Forklift is also equipped with a safety valve in the hydraulic circuit of the lift cylinder to slow the downward speed of the mobile upright that ensures the safety downward movement.

There is a one-way throttle valve at the rear of oil exit of the tilt cylinder. With the appropriate regulating it can choose the tilt speed.

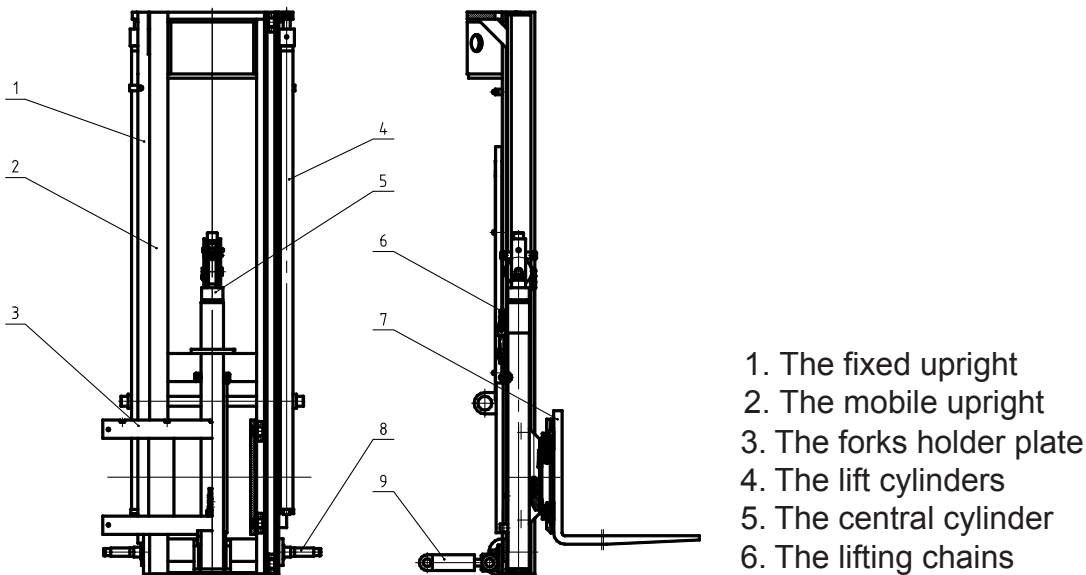

Fig.4 - The Hydraulic Lifting System

## 9.4 Hydraulic pump station

The hydraulic pump station is made up of a motor, pump, oil tank and so on. After the Forklift is used for one year, the oil should be replaced. Replacement could be done as follows:

- Park the Forklift on a flat surface.
- Bring the forks to the lowest position in order for the oil to circulate back to the tank.
- Loosen the lock screws of the footrest and remove the footrest.
- Put the oil dish in the bottom of the oil tank and loosen the sucking oil pipeline to let off the oil.
- Take out the mesh filter from the oil tank and clean it with kerosene.
- Fit the mesh filter on the oil tank and connect the sucking oil pipeline.
- Using the funnel with a mesh filter, pour in oil to about 80% of the oil tank height.
- Reconnect the filler plug and footrest.

## 9.5 Forks and Forks holder plate

The forks holder plate slide on the holder plate to make the forks move up and down. The lift forks holder plate should be checked to inspect if the limit screws on the two sides are operating appropriately. If the limit screws are too tight, the forks holder plate cannot slide freely. If too loose, the forks holder plate will shake. The forks should be checked after 500 hours of usage. Any faulty forks must be taken out of service immediately and cannot be used again until they have been repaired or replaced.

The fence must be fixed after the forks are fitted on the lift forks holder plate. If not, the forks that slide from the two sides of the forks holder plate can lead to malfunctioning.

If the fork thickness has been reduced to 90% of the original thickness due to wear, you must stop using them and need to be replaced immediately.

## 9.6 The Lifting Chain

As there are no fixed rules as regards to the frequency and checking of the chains. If there is a lot of dusts on the chains, the chain should be cleaned and re-lubricated. In the normal case, after having worked for 1000 hours, the chains should be removed and washed, check wear & tear of the chain and measure elongation. If the chains have a lot of wear and elongation exceeds 2%, the chains must be replaced. Replace coupling pin, coupling screw together with their respective nuts when replacing the chains. The chains should be re-lubricated after cleaning and replacing the chains.

## THE BRAKE SYSTEM

### The Foot Brake

When driving the Forklift, if you want to stop the Forklift immediately, take your right foot off the accelerator pedal and press the brake pedal placed in the middle until the Forklift has come to a complete stop.

**Warning: Do not press the accelerator pedal and the brake pedal at the same time, that will burn out the electric component.**

The braking moment of the two wheels in front of the Forklift can be regulated. If the braking is not quite effective, you may adjust by means of steel cables. Tighten screw of steel cables appropriately. If one of the wheel is tight and another wheel is loose, the loose wheel should be adjusted and tightened. Brakes must be adjusted with great care by an experienced technician. The method to do so is as follows:

- Raise the front wheels of the Forklift.
- Remove the footrest.
- Adjust the screw of steel cables on the retainer.
- After adjusting the brake, turn the wheels to see if they are free.
- Simultaneously have another technician press the brake pedal lightly.
- Turn the wheels to inspect the different braking between the two wheels. If one wheel is tight and another wheel is loose, the brakes should be adjusted again.
- Have the technician press the brake pedal hard.
- Rotate the two wheels by hand, and wheels should not turn.

### The hand brake (fig.5)

The hand brake acts as the parking brake. Before carrying out any repair, inspection, or maintenance operations, you should pull the hand brake. The hand brake is at the left side of the front of the Forklift. Pull the hand brake control lever tightly to the inside and press the active button in the center of the hand lever, push the hand lever forward, before releasing the hand lever. If the hand brake is too loose or too tight, it needs to be adjusted. The adjusting method of the hand brake is as that of the foot brake.

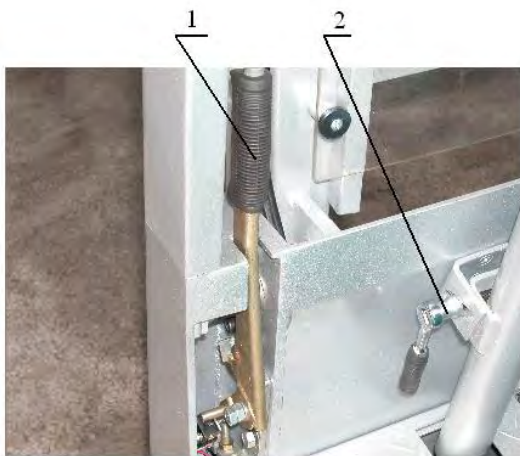

- 1.The hand brake
- 2.The steering column locknut

Fig.4 - The Hydraulic Lifting System

**Note: The Forklift cannot start when pulling the hand brake on.**

## The Energy Recovery Braking

The driving motor is the compound wound dynamo that is a kind of new type for the dynamoelectric counterweight Forklift. The remarkable advantages of the compound wound dynamo are that it can carry out the feedback charging to the battery when the Forklift is coasting to increase work time of the battery, the same time it has the braking function.

The compound wound dynamo can obtain reverse braking current and carry out the feedback charging to the battery in the following cases:

- In the case of downhill slopes.
- Release the accelerator pedal while driving the Forklift

## THE REDUCTION UNIT DRIVE BY ELECTROMOTOR

The reduction unit driven by electromotor is the dynamic system for the Forklift and can carry out changing direction.

The cowling of the reduction unit is made by means of the foundry method. The reduction unit is connected to the frame of the Forklift with the principal axis. The maintenance operation on the reduction unit is checking the oil level in the cowling of the reduction unit to make sure that the oil reaches standard level. If the oil is under the level of the grease cup, oil should be added immediately.

In the normal case, after having worked for 1000 hours, the lubricating oil should be changed in the cowling of the reduction unit.

If the gear case makes an unusual noise, you should park the Forklift and an experienced technician should check the gear case. The damaged bearings or gears may be the cause of the noise. The Forklift can be used after replacing the bearings or repairing the gears.

## THE STEERING SYSTEM

Steering is obtained through the decelerating system for turning to the driving wheels (rear wheels of the Forklift) by turning the steering wheel.

The decelerating system for turning consists of three parts: the reduction unit, the first chain transmission and the second chain transmission.

The adjustment and maintenance to the decelerating system for turning are mainly in the first chain transmission and the second chain transmission. Concrete operating order is as follows:

### Check the first chain transmission

- Remove the footrest.
- Check tightness of the chain by touching the chain with your hand.
- If the chain is loose, loosen the screws on the side of the gear case.
- Use the goring screw fixed in the inner of oil tank to prop up the gear case to move forward to obtain the optimal tension of chain.
- Tighten the screws on the side of the gear case.

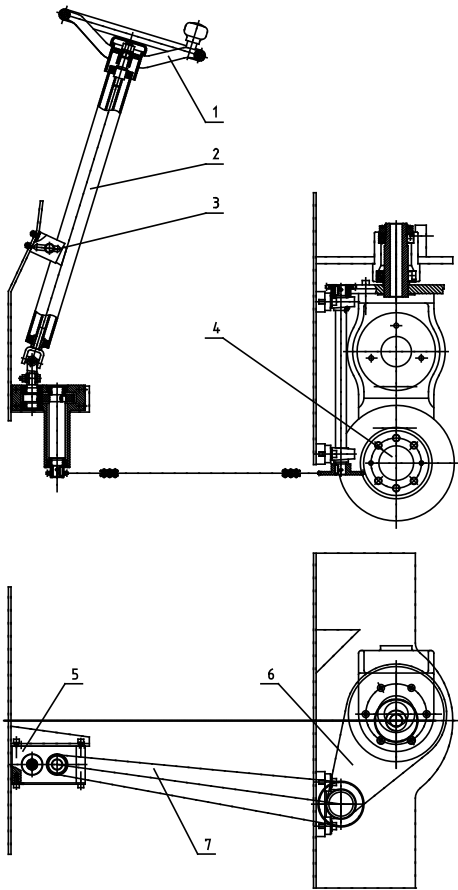

- 1.The steering wheel;
- 2.The steering column;
- 3.The steering column locknut;
- 4.Driving wheel;
- 5.The reduction unit;
- 6.The first chain transmission;
- 7.The second chain transmission

Fig.4 - The Turning System

## Check the Second Chain Transmission

- Loosen the screws of the hinges of the battery cover & remove.
- Loosen the screws used to fix the rear bar of the ROPS and remove.
- Loosen the connection of the rear ballast.
- Lift the rear ballast by about 3-5cm.
- Remove the rear ballast.
- Pull the chain using the screw fixed on the flange to obtain the optimal tension of chain.
- Grease the chain.
- Turn the steering wheel to test whether the steering wheel turn easily.
- Repeat the operations in reverse order indicated above-mentioned to install the parts removed.

**Note:** Before operating the above-mentioned steps make sure that the key has been removed and that the parking brake is on. The rear of the Forklift is blocked with suitable blocks to make the driving wheel turn freely.

## THE WHEELS AND AXLES

The wheels and axles, which are very important for vehicle safety, must be used correctly, assuring periodic inspection and regular maintenance.

Damaged or buckled wheels cannot be forcibly used. The elements should be replaced with others of the same type and size.

The Method of Replacing the Wheels is as follows:

### The removal and installing of the front wheels

- Lift the Forklift with a jack or hoist, keep the Forklift raised with suitable blocks, one per side.
- Remove the center shell of the front wheel.
- Take out the register circlip with a pair of circlip pliers.
- Pull out the wheels.
- Check the axles and bearing making sure that they are in good condition.
- Washing and adding lubricating oil.
- Check the wheels to keep that they are in good condition. Damaged or buckled wheels must be replaced.
- Clean the braking drums in the wheel hubs and remove any oilsmear and dust.
- Repeat the operations in reverse order indicated above-mentioned to install the wheels removed.

### The Removal and Installing of the Rear Wheels

- Block the Forklift with the manual parking brake and block the front wheels.
- Lift the rear of the Forklift with a jack or hoist.
- Chock the rear ballast with a wooden wedge.
- Remove the six fixing nuts of the wheel with the spanner.
- Push out the wheels from the wheels hubs with M10 pushing screw.
- Check and replace the rear wheels
- Install the rear wheels and retighten the six nuts removed.
- Tighten the fixing nuts with the kilogram spanner (The wrest force of the spanner is 20kg) **Warning:**

**The nuts of fixing the rear wheels may become loose because of the various factors. The operators should check tightness of the nuts and tighten the nuts to fasten the wheels to the Forklift.**



# MAIN COMPONENTS

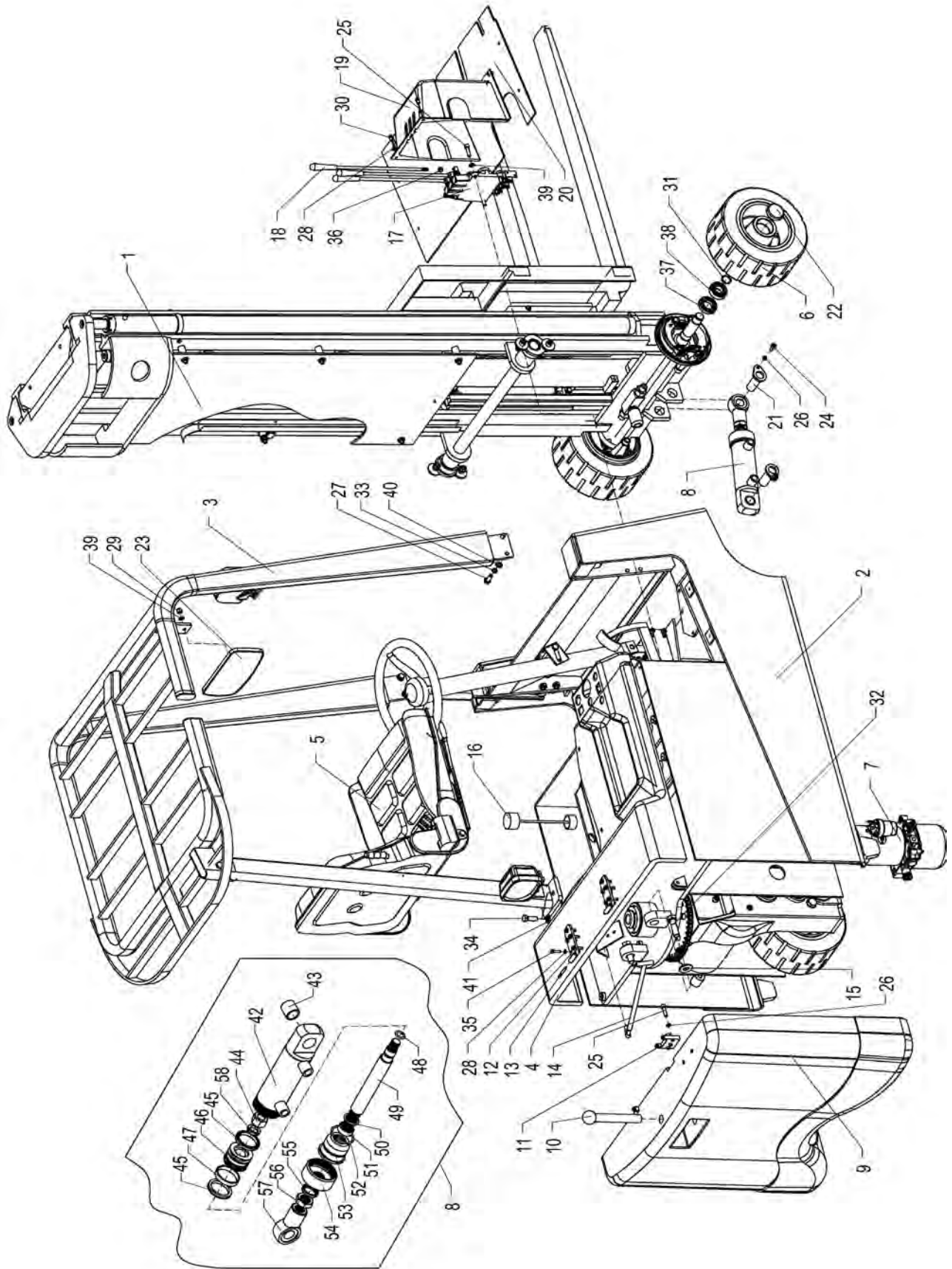

# MAIN COMPONENTS

No.	Part No.	I	Name	Quantity	Replaced part No.	Remarks
1	010000000		Hoisting system	1		
2	020100000		frame	1		
3	020200000		Canopy guard shelves	1		
4	020300000		Battery cover	1		
5	020400000		Seat	1		
6	020500000		Front wheel	2		
7	020600000		Pump station	1		
8	020700000		Tilt cylinder	1		
9	020800000		Balance block	1		
10	020900000		Draft rod	1		
11	021000000		Hinge base	2		
12	021100000		Hinge leaf	2		
13	021200000		Hinge axis	2		
14	021300000		Support	1		
15	021400000		Washer	2		
16	021500000		Oil level scale	1		
17	021600000		Triple control valve	1		
18	021700000		Control rod	3		
19	021800000		Control valve cover	1		
20	021900000		Pedal	1		
21	022000000		Tilt cylinder shaft	2		
22	022100000		Front wheel spindle cover	2		
23	022200000		Rear mirror	1		
24	0600700816		Bolt	6		
25	0600700830		Bolt	9		
26	0600930800		Washer	17		
27	0600931000		Washer	6		
28	0600950600		Washer	14		
29	0608020800		Screw	1		
30	0608180612		Bolt	4		
31	0608942500		Collar	2		
32	0657801655		Bolt	2		
33	0657821025		Bolt	12		
34	0657821235		Bolt	2		
35	0657830625		Bolt	10		
36	0661700800		Screw	8		
37	0800006006		Bearing	2		

# MAIN COMPONENTS

38	0800006205		Bearing	2		
39	0697d10800		Washer	9		
40	0697d11000		Washer	21		
41	0697d11200		Washer	2		
42	0207010000		Sleeve of tilt cylinder	1		
43	0207020000		Bearing sleeve	1		
44	0207030000		Screw	1		
45	0207040000		Seal ring	2		
46	0207050000		Piston	1		
47	0207060000		Guide ring	1		
48	0207070000		Seal ring	1		
49	0207080000		Piston column	1		
50	0207090000		Seal ring	1		
51	0207100000		Guide ring	1		
52	0207110000		Seal ring	1		
53	0207120000		Cylinder head	1		
54	0207130000		Cylinder cover	1		
55	0207140000		Seal ring	1		
56	0207150000		Screw	1		
57	0207160000		Universal joint	1		
58	0600932000		Washer	1		



# DRIVE WHEEL

## Drive wheel

No.	Part No.	I	Name	Quantity	Replaced part No.	Remarks
1	0800006305		Bearing	1		
2	0401010000		Drive wheel housing	1		
3	0401020000		Driving wheel	1		
4	0401030000		Gear 2	1		
5	0401040000		Gear 3	1		
6	0401050000		Splint shaft I	1		
7	0401060000		Gear 6	1		
8	0401070000		Splint shaft II	1		
9	0401080000		Gear 5	1		
10	0401090000		Gear 6	1		
11	0401100000		Fixed screw	1		
12	0401110000		Gasket	1		
13	0401120000		Drive wheel shaft	1		
14	0401130000		Bottom cover	1		
15	0401140000		Fixed screw	6		
16	0401150000		Wheel fixed screw	6		
17	0401160000		Drive wheel	1		
18	0610980316		Key	1		
19	0401170000		Lip sealing ring	1		
20	0800006034		Bearing	2		
21	0800016004		Bearing	1		
22	0800032009		Bearing	2		
23	0657801615		Bolt	2		
24	0657851015		Bolt	1		
25	0661701400		Screw	1		
26	0670d11025		Bolt	1		
27	0670d11065		Bolt	2		
28	0670d10620		Bolt	4		
29	06893d1520		Collar	2		
30	0600931000		Washer	2		
31	0600931400		Washer	1		
32	0909821000		Bonded seal washer	1		
33	0401180000		Top cover	2		
34	0401190000		Top cover	1		
35	0401200000		Sealing gasket	1		
36	0401210000		Motor	1		

# STEERING WHEEL

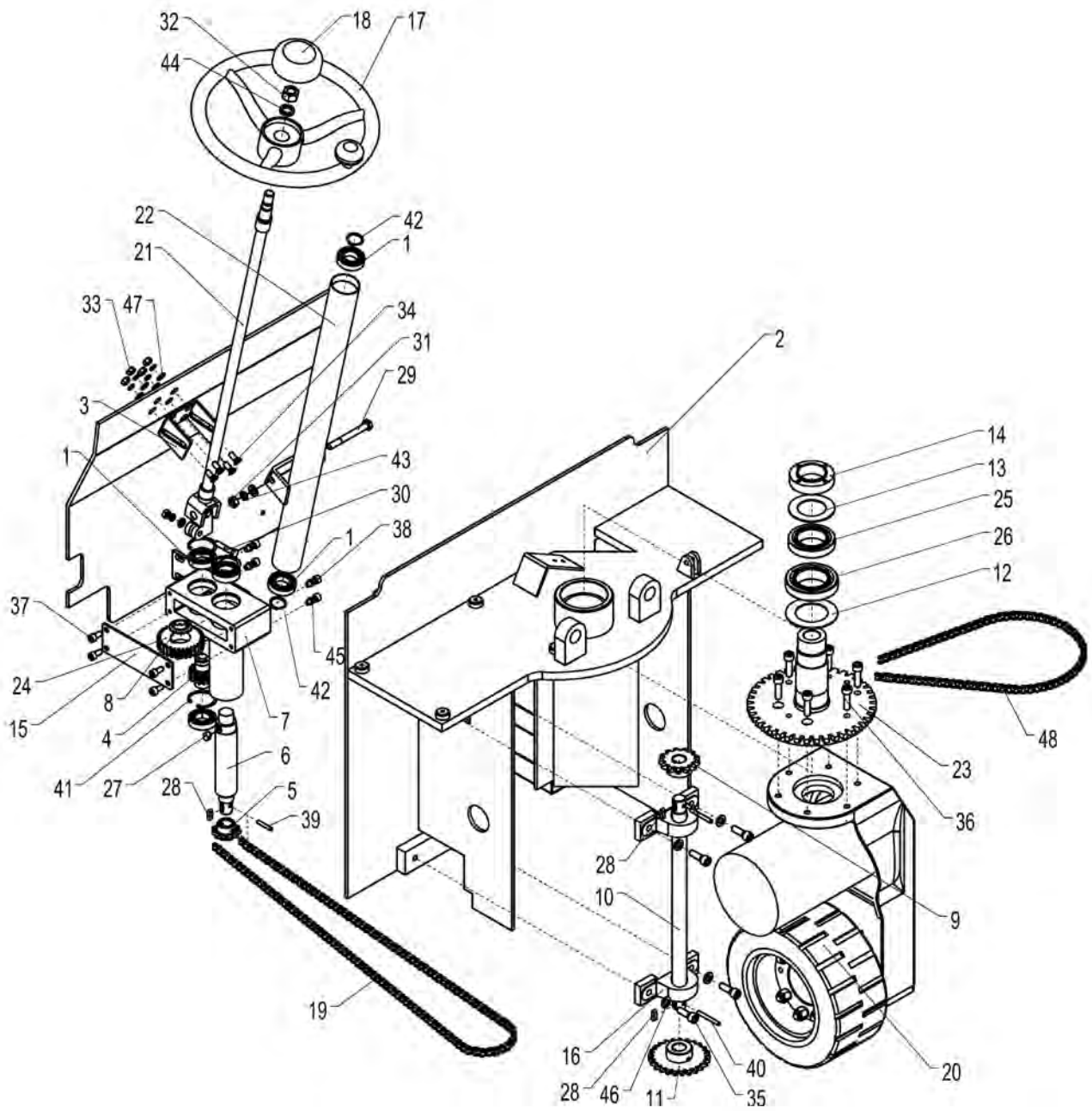

# STEERING WHEEL

No.	Part No.	I	Name	Quantity	Replaced part No.	Remarks
1	0800006005		Bearing	6		
2	0201000000		Frame	1		
3	0301000000		Steering tube seat	1		
4	0302000000		Gear shaft	1		
5	0303000000		Drive chain wheel	1		
6	0304000000		Driving wheel shaft	1		
7	0305000000		Steering gear	1		
8	0306000000		Gear sleeve	1		
9	0307000000		Axle upper chain wheel	1		
10	0308000000		Axle chain wheel shaft	1		
11	0309000000		Axle lower chain wheel	1		
12	0310000000		Lower collar	1		
13	0311000000		Upper collar	1		
14	0312000000		Screw	1		
15	0313000000		Gear box cover	1		
16	0314000000		Bearing seat	2		
17	0315000000		Steering wheel	1		
18	0316000000		Steering wheel cover	1		
19	0317000000		Steering chain I	1		
20	0318000000		Drive device	1		
21	0319000000		Steering shaft	1		
22	0320000000		Steering tube	2		
23	0321000000		Steering eccentric linkage shaft	2		
24	0322000000		Big gear	1		
25	0800032010		Bearing	1		
26	0800032011		Bearing	1		
27	0610961014		Key	1		
28	0610960620		Key	3		
29	0657821090		Bolt	1		
30	0657820840		Bolt	1		
31	0661701000		Screw	1		
32	0661701600		Screw	1		
33	0661700800		Screw	5		
34	0600680816		Bolt	4		
35	0670d11030		Bolt	4		
36	0670d11035		Bolt	6		
37	0670d10816		Bolt	4		
38	0670d10820		Bolt	4		
39	0608790632		Pin	1		

# STEERING WHEEL

40	0608790645		Pin	2		
41	06893d1470		Collar	4		
42	06893d1250		Collar	2		
43	0600931000		Washer	1		
44	0600931600		Washer	1		
45	0600930800		Washer	9		
46	0697d11000		Washer	5		
47	0697d10800		Washer	5		
48	0323000000		Steering chain II	1		



# BRAKE SYSTEM

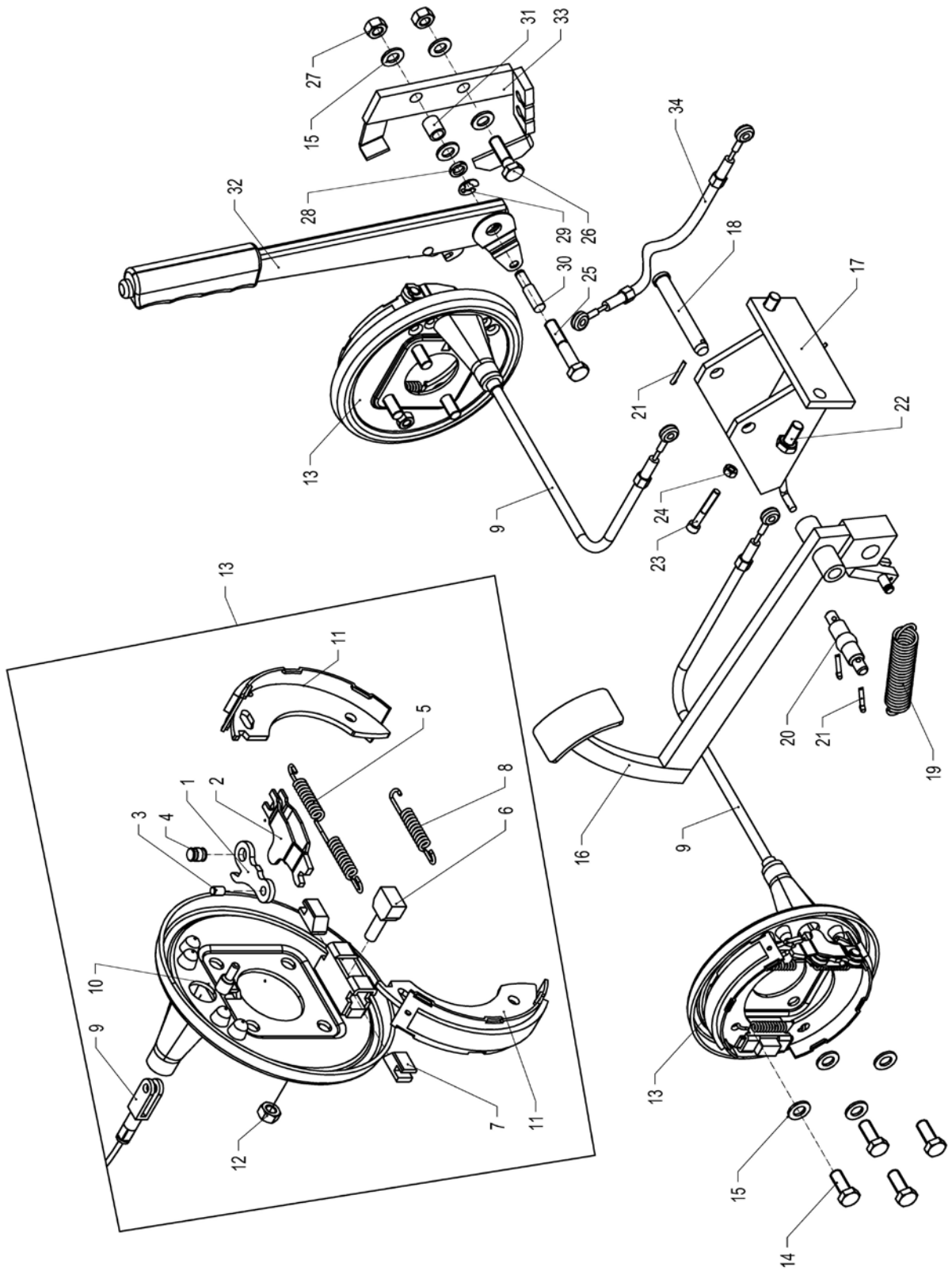

# BRAKE SYSTEM

No.	Part No.	I	Name	Quantity	Replaced part No.	Remarks
1	0501000000		Brake rod	1		
2	0502000000		Seat of brake rod	1		
3	0503000000		Pin	1		
4	0504000000		Positioning pin	1		
5	0505000000		Brake reset return spring I	1		
6	0506000000		Tighten adjusting screw	1		
7	0507000000		Tighten adjusting block	2		
8	0508000000		Brake reset return spring II	1		
9	0509000000		Foot brake wire	2		
10	0510000000		Front wheel breadline	1		
11	0511000000		Brake shoe	2		
12	0512000000		Screw	1		
13	0513000000		Front wheel brake device	2		
14	0657821025		Bolt	8		
15	0697d11000		Washer	12		
16	0514000000		Brake panel	1		
17	0515000000		Pedal brake seat	1		
18	0516000000		Swing arm pin	1		
19	0517000000		Spring	1		
20	0518000000		Brake wire drawing axle	1		
21	0600912516		Pin	3		
22	0657831020		Bolt	2		
23	0600700620		Bolt	1		
24	0661700600		Screw	1		
25	0657821035		Bolt	1		
26	0657821055		Bolt	1		
27	0661701000		Screw	2		
28	0600931000		Washer	1		
29	0608960800		Collar	1		
30	0519000000		wire drawing axle	1		
31	0520000000		Hand brake bearing sleeve	1		
32	0521000000		Hand brake handle	1		
33	0522000000		Hand brake gasket	1		
34	0523000000		Hand brake wire	1		

# HOISTING SYSTEM

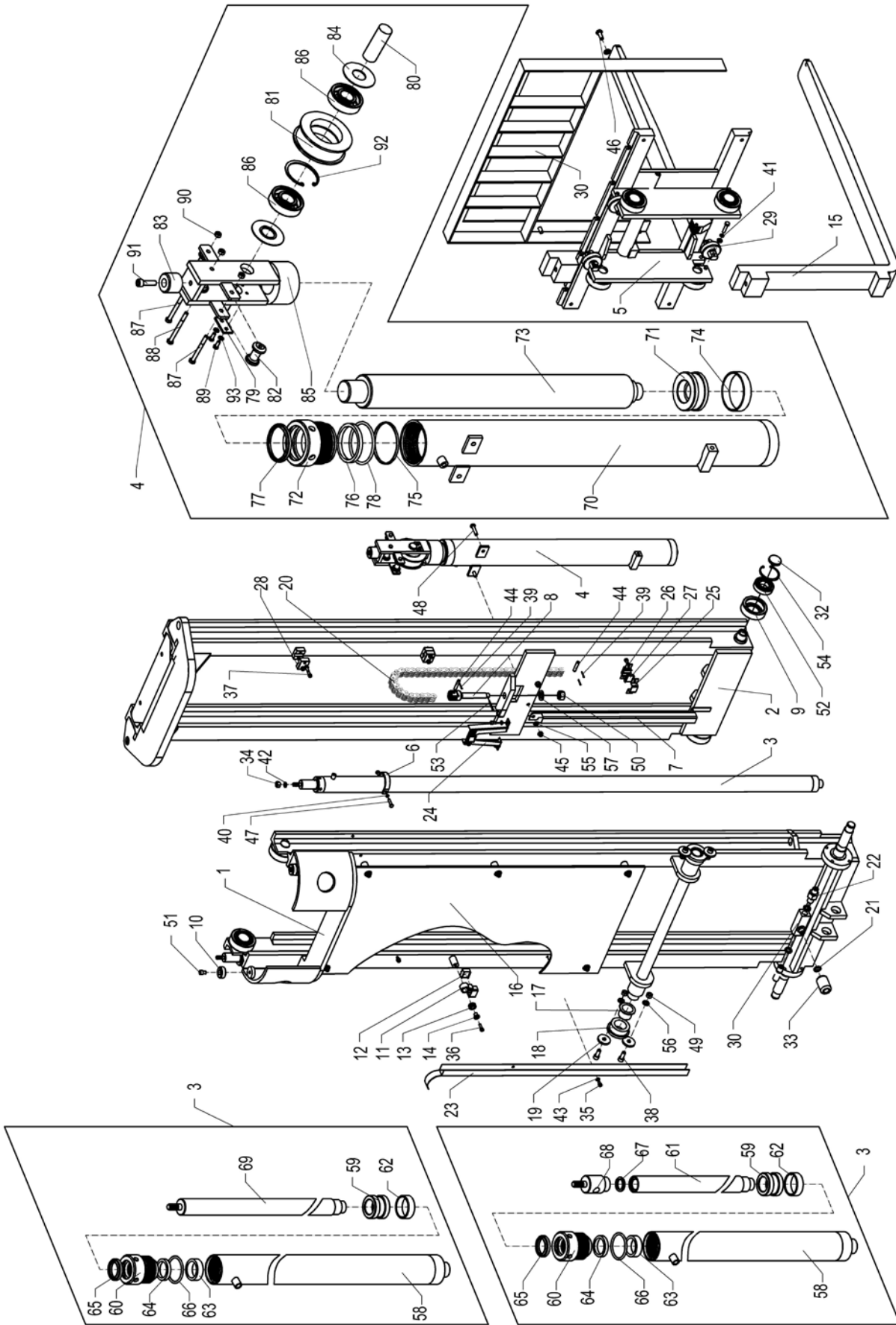

# HOISTING SYSTEM

No.	Part No.	I	Name	Quantity	Replaced part No.	Remarks
1	0101000000		Out door frame	1		
2	0102000000		Inner door frame	1		
3	0103000000		Sides cylinder	2		
4	0104000000		Free-moving slide components	1		
5	0105000000		Slide frame	1		
6	0106000000		Cylinder clamp	2		
7	0107000000		Cylinder protection slot II	1		
8	0108000000		Chain end bolt	1		
9	0109000000		roller	8		
10	0110000000		Cushion gasket I	2		
11	0111000000		Tube positioning components I	2		
12	0112000000		Oil hose rubber block I	2		
13	0113000000		Glass damping ring	6		
14	0114000000		Glass block	6		
15	0115000000		Fork	2		
16	0116000000		Glass panel	1		
17	0117000000		Door frame shaft	2		
18	0118000000		Sleeve of door frame shaft	2		
19	0119000000		Pressure panel for door frame	4		
20	0120000000		Lifting chain	1		
21	09098216d7		Bonded seal washer	3		
22	1008000000		Joint	2		
23	0123000000		Pipe protection slot I	1		
24	0124000000		Pipe clamp bracket	1		
25	0125000000		Pipe clamp panel III	1		
26	0126000000		Pipe clamp panel II	2		
27	0127000000		pipe rubber block II	3		
28	0128000000		Pipe clamp block	4		
29	0129000000		Side roller of slide support	4		
30	0130000000		Support	1		
31	0131000000		Three-way anti-lock valve	1		
32	0132000000		Nylon plate	8		
33	0133000000		Anti-lock valve	1		
34	0600411000		Screw	2		
35	0600700610		Bolt	8		
36	0600700620		Bolt	6		
37	0600700640		Bolt	4		
38	0600701025		Bolt	4		
39	0600910216		Collar pin	4		

# HOISTING SYSTEM

40	0600930600	Washer	4		
41	0600930800	Washer	8		
42	0600931000	Washer	2		
43	0600950600	Washer	12		
44	0608800840	Pin	2		
45	0608890800	Screw	2		
46	0657821025	Bolt	4		
47	0657830625	Bolt	4		
48	0657830835	Bolt	10		
49	0661701000	Screw	4		
50	0661701600	Screw	1		
51	0661910812	Bolt	2		
52	0800006206	Bearing	8		
53	060913d228	Collar pin	1		
54	06893d1620	Collar	8		
55	0697d10800	Washer	10		
56	0697d11000	Washer	8		
57	0697d11600	Washer	1		
58	0103010000	Sides cylinder gasket	1		
59	0103020000	Sides cylinder piston	1		
60	0103030000	Sides cylinder head	1		
61	0103040000	Piston rod	1		
62	0103050000	Guide ring	1		
63	0103060000	Guide ring	1		
64	0103070000	Seal ring	1		
65	0103080000	Dust-proof ring	1		
66	0103090000	Seal ring	1		
67	0103100000	Seal washer	1		
68	0103110000	Piston rod end	1		
69	0103040001	Piston rod	1		
70	0104010000	Middle external oil tank	1		
71	0104020000	Middle oil tank piston	1		
72	0104030000	Middle oil tank head	1		
73	0104040000	Middle piston rod	1		
74	0104050000	Piston ring	1		
75	0104060000	Seal washer	1		
76	0104070000	Washer	1		
77	0104080000	Dust-proof ring	1		
78	0104090000	O-ring	1		
79	0104100000	Roller shaft support	1		
80	0104110000	Chain roller shaft	1		
81	0104120000	Chain roller	1		
82	0104130000	Pipe roller	3		

# HOISTING SYSTEM

83	0104140000		Buffering washer II	1		
84	0104150000		Collar	2		
85	0104160000		Middle oil tank top seat	1		
86	0800006305		Bearing	2		
87	0657820660		Bolt	2		
88	0657820670		Bolt	1		
89	0657820512		Bolt	2		
90	0661700600		Screw	3		
91	0670d10830		Bolt	1		
92	06893d1620		Collar	1		
93	0697d10500		Washer	2		

# ELETRICAL SYSTEM

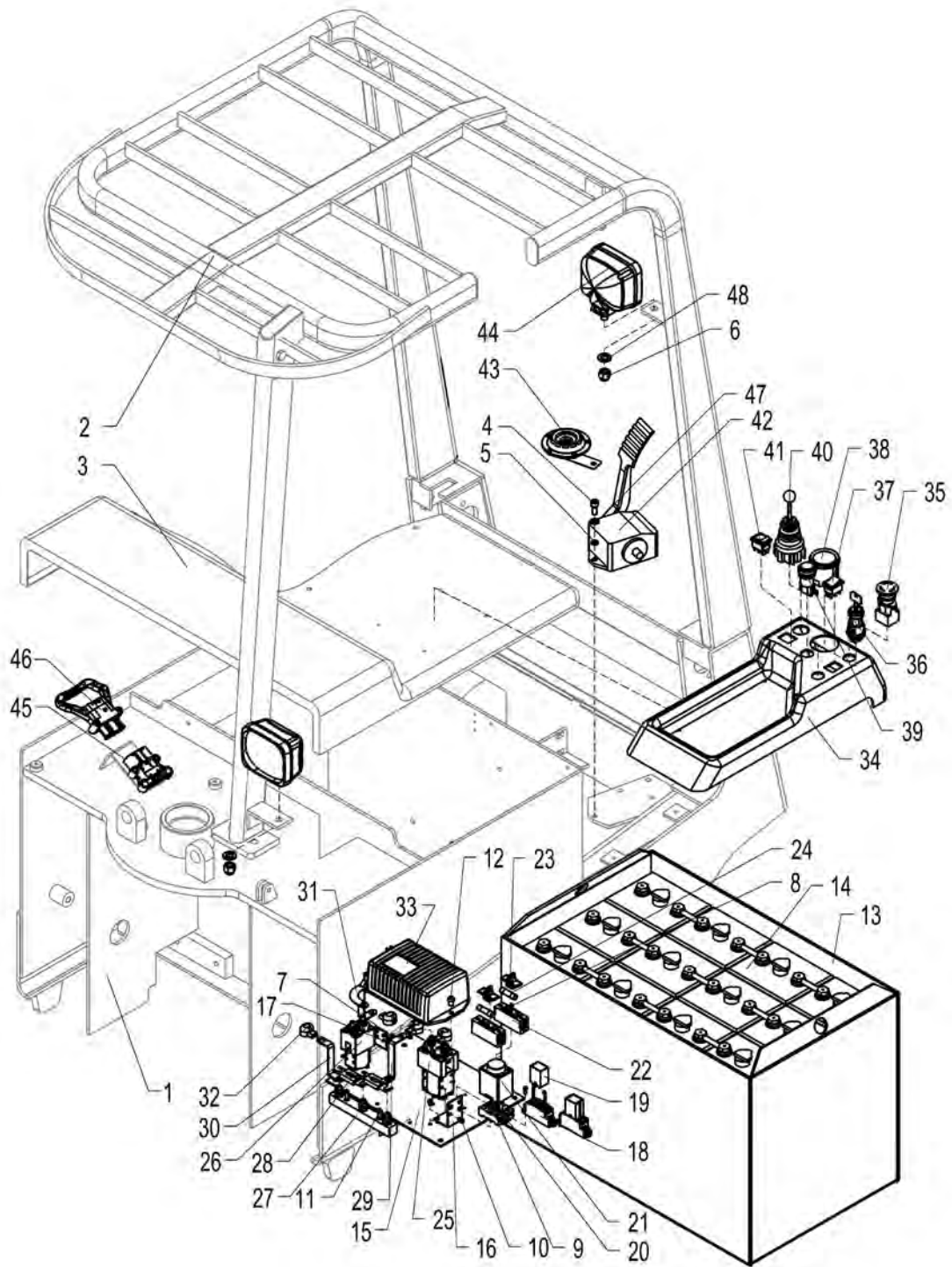

# ELETRICAL SYSTEM

No.	Part No.	I	Name	Quantity	Replaced part No.	Remarks
1	0201000000		Frame	1		
2	0202000000		Canopy guard shelves	1		
3	0203000000		Battery cover	1		
4	0600700820		Bolt	2		
5	0600930800		Washer	2		
6	0608021200		Screw	2		
7	0608180408		Bolt	4		
8	0608180412		Bolt	6		
9	0608180420		Bolt	2		
10	0608180508		Bolt	8		
11	0608180516		Bolt	2		
12	0608180612		Bolt	3		
13	0700000100		Battery box	1		
14	0700000200		Battery pack	1		
15	0700000300		Electric installation panel	1		
16	0700000400		contactor panel 2	1		
17	0700000500		contactor panel 1	1		
18	0700000600		Relay seat	2		
19	0700000700		Relay	2		
20	0700000800		Time relay seat	1		
21	0700000900		Time relay seat	1		
22	0700001000		Fuse seat	2		
23	0700001100		Fuse cover	2		
24	0700001200		Fuse	2		
25	0700001300		Contactor 2	1		
26	0700001400		Contactor 1	1		
27	0700001500		Seat for safety leaf installing	1		
28	0700001600		Safety leaf	2		
29	0700001700		Copper busbar	1		
30	0700001800		Copper busbar	1		
31	0700001900		Copper busbar	1		
32	0700002000		Guard sleeve	4		
33	0700002100		controllor	1		
34	0700002200		Operation panel	1		
35	0700002300		Emergency switch	1		
36	0700002400		Power switch	1		
37	0700002500		Switch	1		



# ELETRICAL SYSTEM

38	0700002600		Power meter	1		
39	0700002700		Horn switch	1		
40	0700002800		Operation handle	1		
41	0700002900		Switch,	1		
42	0700003000		accelerator	1		
43	0700003100		Horn	1		
44	0700003200		Illuminator	2		
45	0700003300		Socket	1		
46	0700003400		Plug	1		
47	0697d10800		Washer	2		
48	0697d11200		Washer	2		

# HYDRAULIC SYSTEM

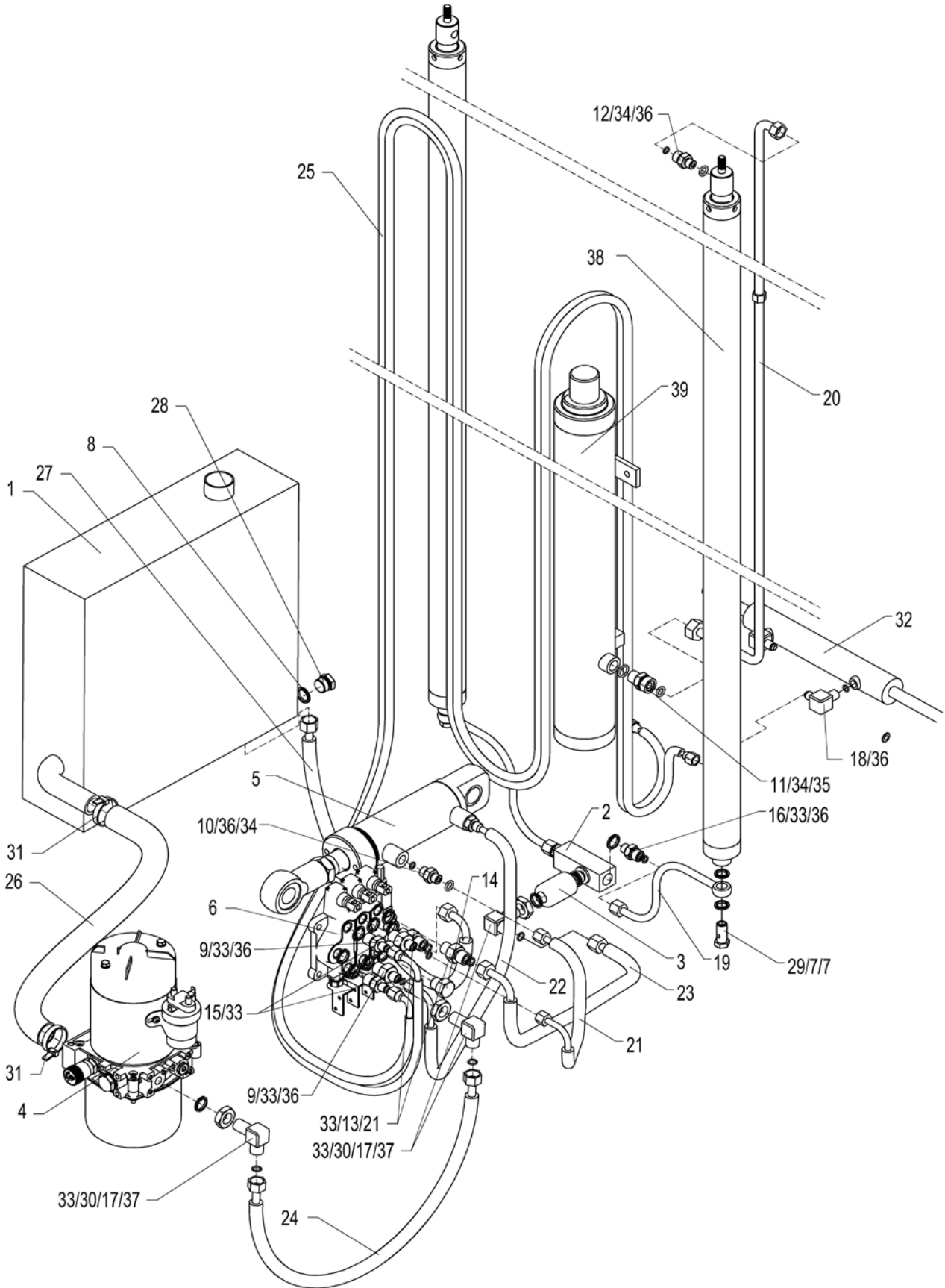

# HYDRAULIC SYSTEM

No.	Part No.	I	Name	Quantity	Replaced part No.	Remarks
1	0201000000		Main oil tank	1		Welded on the frame
2	0131000000		Three-way anti-lock valve	1		
3	0133000000		Anti-lock valve	1		
4	0206000000		Pump station	1		
5	0207000000		Tilt cylinder	1		
6	0216000000		Triple control valve	1		
7	0909820014		Bonded seal washer	4		
8	0909820018		Bonded seal washer	1		
9	1001000000		Joint	2		
10	1002000000		Joint	2		
11	1003000000		Joint	1		
12	1004000000		Joint	1		
13	1005000000		Joint	2		
14	1006000000		Plug	1		
15	1007000000		Joint	2		
16	1008000000		Joint	2		
17	1009000000		Joint	3		
18	1010000000		Joint	2		
19	1011000000		Oil pipe	1		
20	1012000000		Oil pipe	1		
21	1013000000		Oil pipe	1		
22	1014000000		Oil pipe	1		
23	1015000000		Oil pipe	1		
24	1016000000		Oil pipe	1		
25	1017000000		Oil pipe	1		
26	1018000000		Oil pipe	1		
27	1019000000		Oil pipe	1		
28	1020000000		Bolt	1		
29	1021000000		Bolt	2		
30	1022000000		Screw	3		
31	1023000000		Clamp	2		
32	1024000000		Side shift cylinder	1		
33	09098216d7		Bonded seal washer	13		
34	0910d62d65		O-ring	4		
35	0914002d65		O-ring	1		
36	097d101d80		O-ring	9		
37	099d501d80		O-ring	5		
38	0103000000		Side oil cylinder	2		
39	0104000000		Free-moving slide components	1		



# WARRANTY

## Limited Warranty

The manufacturer warrants that products manufactured shall be free from defects in material and workmanship that develop under normal use for a period of one year on all products from the date of shipment. The foregoing shall be the exclusive remedy of the buyer and the exclusive liability of the manufacturer. Our warranty excludes normal replaceable wear items, i.e. gaskets, wear parts, seals, O-rings, belts, drive chains, clutches, etc. Any equipment, part or product which is furnished by the manufacturer but manufactured by another, bears only the warranty given by such other manufacturer. (Manufacturer agrees to furnish free of charge a written description of problem or cause.) Warranty is voided by product abuse, alterations, use of equipment in applications for which it was not intended, use of non-manufacturer parts, or failure to follow documented service instructions. The foregoing warranty is exclusive of all other warranties whether written or oral, expressed or implied. No warranty of merchantability or fitness for a particular purpose shall apply. The agents, dealers, and employees of Manufacturer are not authorized to make modifications to this warranty, or additional warranties binding on the Manufacturer. Therefore, additional statements, whether oral or written, do not constitute warranty and should not be relied upon.

The Manufacturer's sole responsibility for any breach of the foregoing warranty provisions, with respect to any product or part not conforming to the Warranty or the description herein contained, is at its option (a) to repair, replace, or refund such product or parts upon the prepaid return thereof to location designated specifically by the Manufacturer. Product returns not shipped prepaid will be refused (b) as an alternative to the foregoing modes of settlement - the Manufacturer's dealer may repair defective units with reimbursement for expenses. A written description of problem or cause must accompany all warranty claims.

Except as set forth here in above and without limitation of the above, there are no warranties or other affirmation which extend beyond the description of the products on the fact here of, or as to operational efficiency, product reliability, or maintainability or compatibility with products furnished by others. In no event, whether as a result of breach of contract or warranty or alleged negligence, shall the Manufacturer, be liable for special or consequential damages including but not limited to: Loss of profits or revenue, loss of use of the product or any associated product, cost of capital, cost of substitute products, facilities or services or claims of customers. Manufacturer does not assume responsibility for any accident due to equipment modification.

No claim will be allowed for products lost or damaged in transit. Such claims should be filed with the carrier within fifteen days.

Effective July 20, 2005

EZG Manufacturing is the exclusive manufacturer of the patented Grout Hog® Grout Delivery System the Mud Hog® Hydraulic Mixing Station, the Hog Trough® mud pan, the Hog Cart™, the Hog Slopper™, the Booger Hog® Wall Scrubber, the Hog Leg® Wall Brace System, and the Hog Crusher™ Material Recycling System.

# WARRANTY REGISTRATION

Fax Warranty Registration form to 740-962-2037  
or submit online at [www.ezgmfg.com](http://www.ezgmfg.com) by clicking on  
"Products" then "Warranty Cards"

CONTACT: \_\_\_\_\_  
COMPANY: \_\_\_\_\_  
ADDRESS: \_\_\_\_\_  
CITY: \_\_\_\_\_ STATE \_\_\_\_\_ ZIP \_\_\_\_\_  
PHONE: \_\_\_\_\_ FAX \_\_\_\_\_ CELL \_\_\_\_\_  
EMAIL: \_\_\_\_\_  
PURCHASED FROM:  Direct  Distribution \_\_\_\_\_  
PURCHASED DATE: \_\_\_\_\_ SERIAL NO. \_\_\_\_\_

PLEASE COMPLETE THIS WARRANTY CARD AND RETURN VIA MAIL, FAX OR E-MAIL  
WITHIN 30 DAYS OF PURCHASE TO VALIDATE YOUR MANUFACTURER'S WARRANTY  
FOR ALL EZG MANUFACTURING PRODUCTS.  
WARRANTY PROVISIONS OF THIS MACHINE ARE HANDLED DIRECTLY THROUGH  
THE MANUFACTURER.

EZG MANUFACTURING \* 1833 North Riverview Road, Malta, OH 43758 \*  
PHONE 1-800-417-9272 \* Email: [warranty@ezgmfg.com](mailto:warranty@ezgmfg.com) \* FAX 740-962-2037

*Please take a minute to fill out the survey below so that we better serve our customers.*

## Survey

- WHERE DID YOU FIRST HEAR ABOUT EZG MANUFACTURING (CHECK ONE)  
 Masonry Magazine  Website  Newsletter  Referral  Masonry Construction  
 Other: \_\_\_\_\_
  - WHAT INFLUENCED YOU TO BUY?  QUALITY  PRICE  EASY TO USE  OTHER
  - WHO IS YOUR SALES REPRESENTATIVE? \_\_\_\_\_
  - ARE YOU SATISFIED WITH THE CUSTOMER SERVICE YOU RECEIVED?  YES  NO  
Explain: \_\_\_\_\_
  - WHAT OTHER EZG MANUFACTURING PRODUCTS DO YOU OWN?  
\_\_\_\_\_  
\_\_\_\_\_
  - WOULD YOU LIKE TO BE FEATURED IN OUR NEWSLETTER?  YES  NO  
If yes, where can we reach you and what is the best time?  
\_\_\_\_\_  
\_\_\_\_\_
- Comments: \_\_\_\_\_  
\_\_\_\_\_  
\_\_\_\_\_